



EAST TOWER



AYIA NAPA
MARINA

by **OGA**

SEA INSPIRING LIVING



This unique development is
BROUGHT TO LIFE BY ORA

ORA is a leading name in the field of designing and developing luxury lifestyle destinations in unique locations. We bring world-class expertise, exceptional attention to detail and visionary ideas to every landmark project we work on.



ORA was established in 2016 by Engineer Naguib Sawiris with the vision to seek out new opportunities in untapped locations and to create unique lifestyle destinations.

Eng. Naguib has been described as one of the most influential business people of his generation.

Widely respected for his work in the telecommunication sector, his vision and insight has helped create a number of world-class businesses.

His leading roles range from establishing Orascom Telecom Holding (OTH), which was acquired by VEON to create the world's sixth largest telecommunication firm, to heading up, chairing and advising market-changing companies in the financial services, energy, agro-industries, logistics and real estate sectors.

NAGUIB SAWIRIS
Chairman & CEO



Ayia Napa Marina



Eighteen



Silversands



Solana



Yi



ZED



ORA operates in multiple locations around the world between Egypt, Cyprus, Greece, Grenada, and Pakistan and is expanding to the United Arab Emirates.

ORA Properties offers mixed-use developments such as ZED, Solana, Ayia Napa Marina and Eighteen, while ORA Hospitality develops and manages Silversands and Yi Hotels in Grenada and Mykonos with an expansion that will reach UAE and different parts of Africa.

Our expanding portfolio of projects spans a rich variety of stunning developments in select locations around the world.



SILVERSANDS



AYIA NAPA MARINA



PYRAMID HILLS



EIGHTEEN



Yi HOTEL



SOLANA



Reimagining Time

oradevelopers.com

LUXURY RESIDENTIAL APARTMENTS

Ayia Napa Marina captures the true essence of modern seafront living in the Eastern Mediterranean.

The marina offers a selection of luxury residences thoughtfully designed to provide comfortable spacious modern living with uninterrupted panoramic views of the Mediterranean Sea.

Rising high above the marina are two iconic towers, visible from both land and sea. Over 100 meters tall, the East Tower and West Tower stand out in splendour like beacons welcoming seafarers, residents and visitors alike.



WORLD-CLASS MARINA

Raising the benchmark for marina services, Ayia Napa Marina is the new premier yachting destination in the Mediterranean.

Ayia Napa Marina offers world-class yachting facilities in a superb Mediterranean island location.



BEACHFRONT LIVING

23 luxury villas are located along privately maintained and secured roads on the marina island.

The villa architecture is a contemporary expression of new and old, combining locally quarried stone around the base with sleek plaster volumes cantilevered above. All villas are designed with a modern, open-plan concept, with primary spaces oriented towards the sea.



**LUXURY
BEACHFRONT
LIVING**



BERTH
YOUR BOAT AT
YOUR VILLA



**UNIQUE
TWISTING
TOWERS**



SAFE AND SECURE

Residents are ensured peace of mind thanks to Facility Management Services and round the clock security.



MASTERPLAN



VILLAS

BEACH VILLAS 1
– 11 villas with infinity edge pools

ISLAND VILLAS 2
– 12 villas with private berths and infinity edge pools

MARINA SUITES 3
– Luxury marina suites

WEST TOWER

– 125 luxurious apartments 4

EAST TOWER

– 95 luxurious apartments 5

COMMERCIAL VILLAGE

COMMERCIAL VILLAGE 6
– 4,000m² + of commercial space
– Restaurants & coffee shops
– Retail stores
– Recreational activities
– Convenience store & pharmacy
– Chandlery
– SPA & fitness facilities

EVENT CENTRE & PLAZA 7
– The ideal setting for indoor & outdoor events

FESTIVAL PIER 8
– Extension of the event centre

BEACH CLUB 9
– Bar & lounge area

CAR PARKING SPACES 10
– 550+ public parking spaces

MARINA

SUPER YACHT MARINA 11
– 600 yachts (max berth size: 110m)
– 360 state of the art wet slips
– 80 spaces on the Dry Dock
– Finger pier berthing
– Refueling station
– Power & water supply
– Sewage pump-out facilities
– Fiber optics & Wi-Fi facilities

DRY STACK & BOAT YARD 12
– 160 spaces on the Dry Stack storage (max size: 10m)
– Boat yard
– Boat hauling & rigging
– 150-ton travel hoist
– Maintenance building
– Chandlery & crew members lounge

YACHT CLUB 13
– Amenities, including showers, changing rooms & WC

COMFORT STATION 14
– Amenities, including showers, changing rooms & WC

SOUTH BREAKWATER AND CROWN WALL 15

GOVERNMENT BUILDING 16
– The marina is an official port of entry for Cyprus
– Government Services: Police, Customs, Immigration, Medical Services, Veterinary Services

HARBOUR MASTER BUILDING 17

NATURE

BEACHES 18
– Two beautiful, serviced beaches, with crystal clear water and golden sand

OLIVE GROVE 19

NATURA 20
– Existing protected native landscape & animal area

AMENITIES

- 24h reception and concierge services
- Property management
- Rentals
- Swimming pools
- Gardens
- Child care
- 24/7 security
- Gated resort
- Valet services
- Serviced beaches
- First aid

FLIGHT TIME FROM KEY CITIES

Cairo	1h 15m
Moscow	3h 40m
Athens	1h 45m
London	4h 45m
Paris	4h 45m
Rome	3h 15m
Brussels	4h 05m
Vienna	3h 30m
Dubai	3h 40m
Riyadh	5h 15m
Beijing, China	13h 15m
Hong Kong	13h
Hanoi, Vietnam	12h
Mumbai, India	8h 50m
Johannesburg	12h 25m



A superb
LOCATION

Strategically located in the eastern Mediterranean at the crossroads of three continents – Europe, Asia and Africa – Cyprus is a safe haven blessed by beautiful nature, all year-round sunshine, modern infrastructure, a high standard of living and a genuine culture of warmth and hospitality.

Fully compliant with EU laws and regulations, Cyprus' simple and

transparent tax system is one of the most attractive in Europe. Its modern legal system, based on English Common Law, is widely recognized as being effective and business friendly.

The modern, competitive and simple business environment coupled with a high quality of life make Cyprus an ideal place for both visitors and investors.

CONVENIENT CONNECTIVITY

Easily accessible from the island's major highways and approximately 30 minutes' drive from Larnaca International airport, Ayia Napa Marina benefits from a convenient location, and excellent connections to key cities around the world.





The ultimate
**MEDITERRANEAN
LIFESTYLE**

Ayia Napa Marina is ideally situated on the south-eastern coast of Cyprus. This exclusive integrated resort offers luxurious residences, world-class yachting facilities, a variety of retail boutiques, waterfront fine dining options, recreational and nightlife experiences.

Its unique location, crystal clear seas, stunning beaches and incredible views combine to entice boaters, visitors and residents who appreciate a lifestyle of class and elegance.

With complete privacy and round-the-clock security for homes and yachts, Ayia Napa Marina is the ideal yachting, social and residential destination, offering everything one needs to relax and enjoy the exciting lifestyle of the Mediterranean.

Ayia Napa Marina is the ultimate lifestyle resort – an international

destination of choice that combines outstanding property investment opportunities with superb views and exceptional yachting facilities.

Designed by US-based architecture, engineering and planning firm, SmithGroupJJR, Ayia Napa Marina boasts 220 luxurious apartments in two iconic, twisting towers; 23 luxury villas; a 600-berth, full service marina and boatyard; a collection of elegant retail, waterfront dining and premium lifestyle amenities for residents and visitors.

A man and a woman are walking away from the camera on a sandy beach. The man is on the left, wearing a light-colored short-sleeved shirt and shorts. The woman is on the right, wearing a light-colored long-sleeved shirt, dark leggings, and a large white sun hat. A large, fluffy white dog is walking between them. The background shows the ocean and a clear sky.

Explore the MAGIC OF CYPRUS

Phenomenal weather, gorgeous golden sandy beaches and crystal-clear waters have transformed Ayia Napa, located on the south-east coast of Cyprus, from a fishing village into one of the top holiday destinations in the Mediterranean.

The town's most prominent building is a 16th century monastery, part of UNESCO heritage, which stands in the central square. A few minutes further along the coast, the stunning architecture of luxury lifestyle destination Ayia Napa Marina creates a brand-new landmark.

Sustainability sits at the core of this resort, with a range of initiatives and activities ensuring that its development proceeds in the most environmentally aware way.

Thanks to its geographic location and topography, the Ayia Napa

region is home to several EU Natura sites. Foremost among these is the breathtaking Cape Greco National Forest Park, which is home to a wealth of fauna and flora, such as juniper trees, wild orchids, foxes, hares, hedgehogs and over 80 species of birds.

Famous for its stunning coastline, rocky protrusions, secluded coves, sea caves and amazing cliff peak views, Famagusta District is one of the most favored destinations. It is home to 26 Blue Flag beaches, which is a lot more than any other district in Cyprus.



A lifestyle
DESTINATION

Ayia Napa Marina is the lifestyle destination of choice in Cyprus, a welcoming and relaxing beachfront community that offers world-class dining, leisure, events and retail experiences.



220 apartments



23 beach & island villas



600 berths



Shops & restaurants



Serviced beaches



Biggest beachfront development in Cyprus



Cyprus 1st twisting towers



Secured and gated community



Yacht club & beach club



Fitness facilities & Spa



Panoramic views of the Mediterranean sea and the marina



Top tourist destination



Property management & rental program



Fully financed



High returns



Elegant modern living with
UNIQUE BENEFITS



Full member of EU and Eurozone



Strategic geographical location
 At the crossroads of 3 continents – Europe, Asia, Africa



Modern banking and legal system based on the British common law



Pro-business environment



Stable political environment



Excellent infrastructure



Favourable EU approved tax regime



12.5% corporate tax



Non-domicile principle



Largest number of blue flag beaches per coast line in the world



65+ double taxation treaties



0% Tax on dividends to non-residents
 0% Immovable property tax
 0% Inheritance tax



High quality of life



Mediterranean climate
 24°C average annual temperature.
 300+ sunny days.



Multicultural



High level of education



Safety
 Cyprus is officially one of the safest countries in the world!



69 blue flag beaches



Top tourist destination



13 Universities
 30+ International Schools

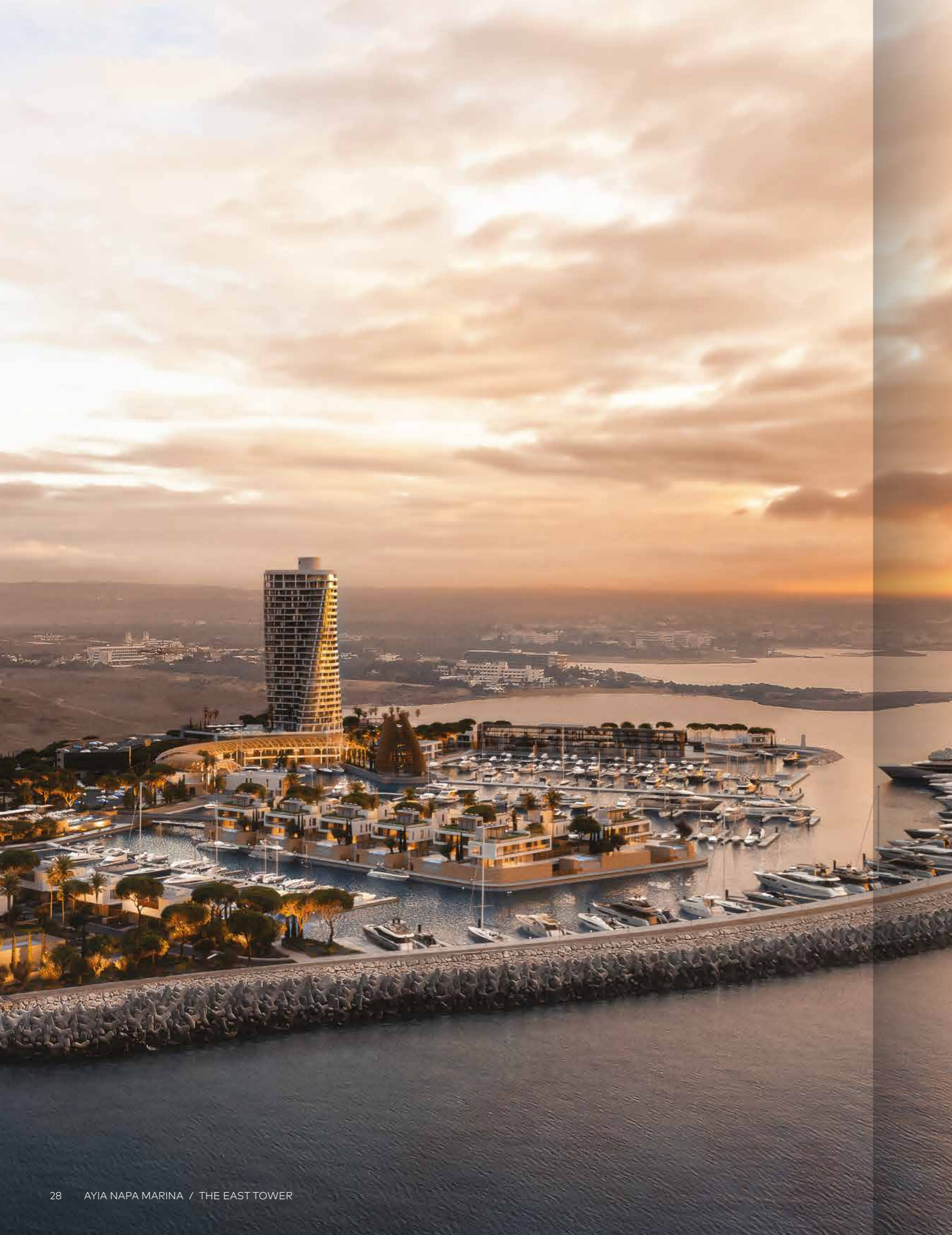

EAST TOWER

Luxury
VIBRANT LIVING

Rising above the marina on the east side, one of two iconic twisting towers, visible from land and sea.

The East Tower is located at the commercial hub of the marina offering a vibrant and bustling environment for residents and guests.

Its spacious lobby has an undulating sculptural ceiling soaring 12 metres above the floor and is surrounded by an all-glass exterior curtain wall with structural glass mullions. This allows an abundance of natural light to flow in and offers a direct view of the commercial area and Event Centre.

Each of the 95 spacious apartments is uniquely shaped to ensure that all living spaces, including bedrooms, are oriented toward the water and beaches – with modern, open plan designs maximizing the daylight and views. The living rooms have full-

height glass doors that open wide to extend the living area out onto the covered veranda. The apartments are ranging from a mix of 1, 2, 3 or 4 - bedroom residences, to full-floor penthouse apartments at the top two floors, that feature 360-degree panoramic views. Residents of the three radiused-end apartments enjoy 180-degree views.

Just steps away from their front door, residents can enjoy the tower's wide array of services and facilities. These include an expansive amenity deck, located on the 3rd floor, overlooking the marina and the sea with an infinity edge pool, cabanas and an outdoor bar. Fitness facilities and a 400m² spa are also available for recreation and relaxation.

TENURE

*The properties are offered as leasehold, the term for which ends on 27/04/2139.
On expiry, the client will have first right of refusal to renew.*

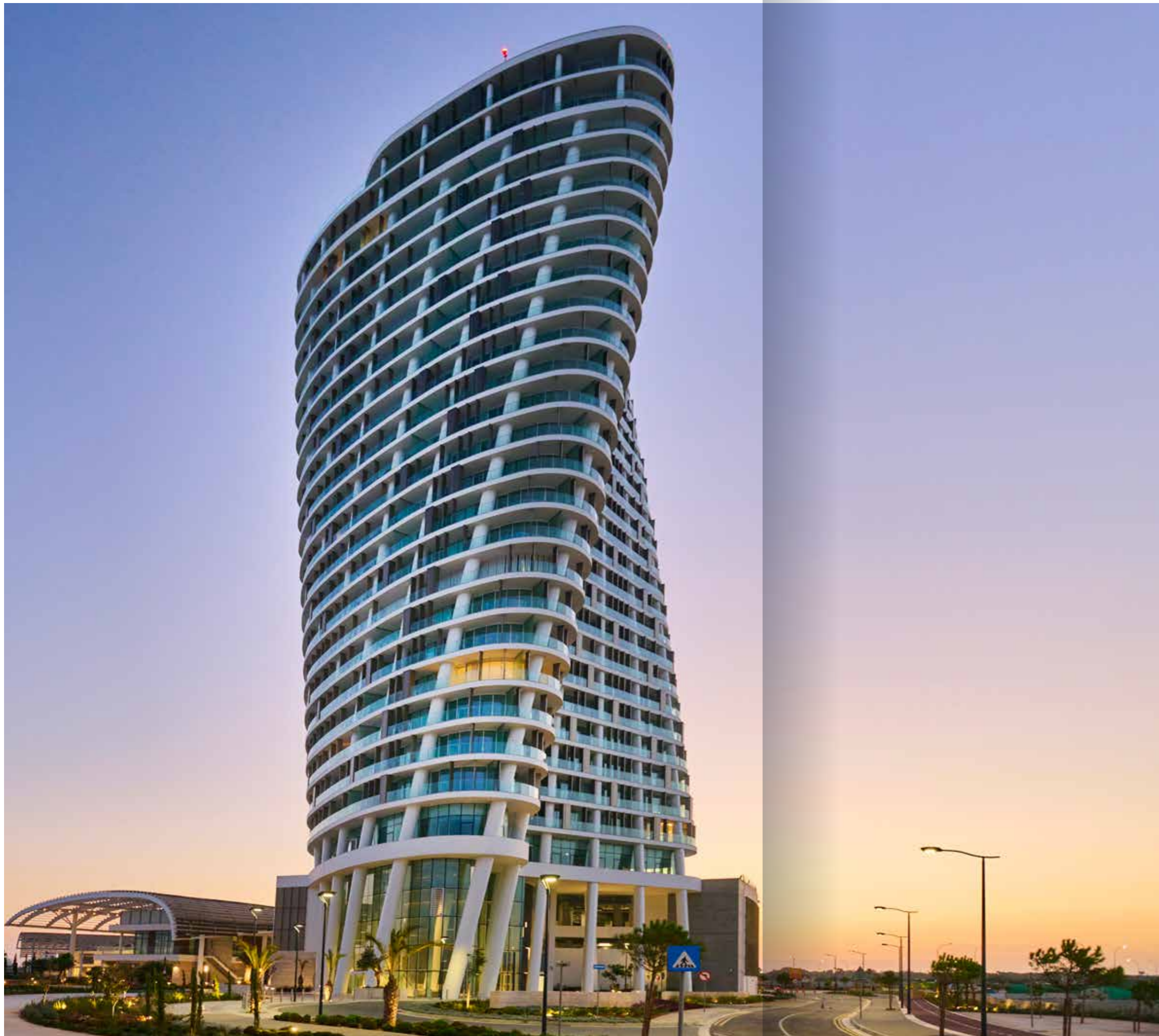

Luxurious modern, open plan interiors maximize daylight and glorious views. Your dream residence is ready to move in.



EAST TOWER

FLOORS 25-26 APARTMENT TYPE
PENTHOUSES 4B, 4C

FLOORS 22-24 APARTMENT TYPES
2A, 2Cw, 3Ae, 3Aw, 4A

FLOORS 11-21 APARTMENT TYPES
**1A, 2A, 2B, 2Ce, 2Cw
3Ae, 3Aw, 3B**

FLOORS 1-9 APARTMENT TYPES
1A, 1B, 2A, 2B, 2Ce, 2Cw, 3B

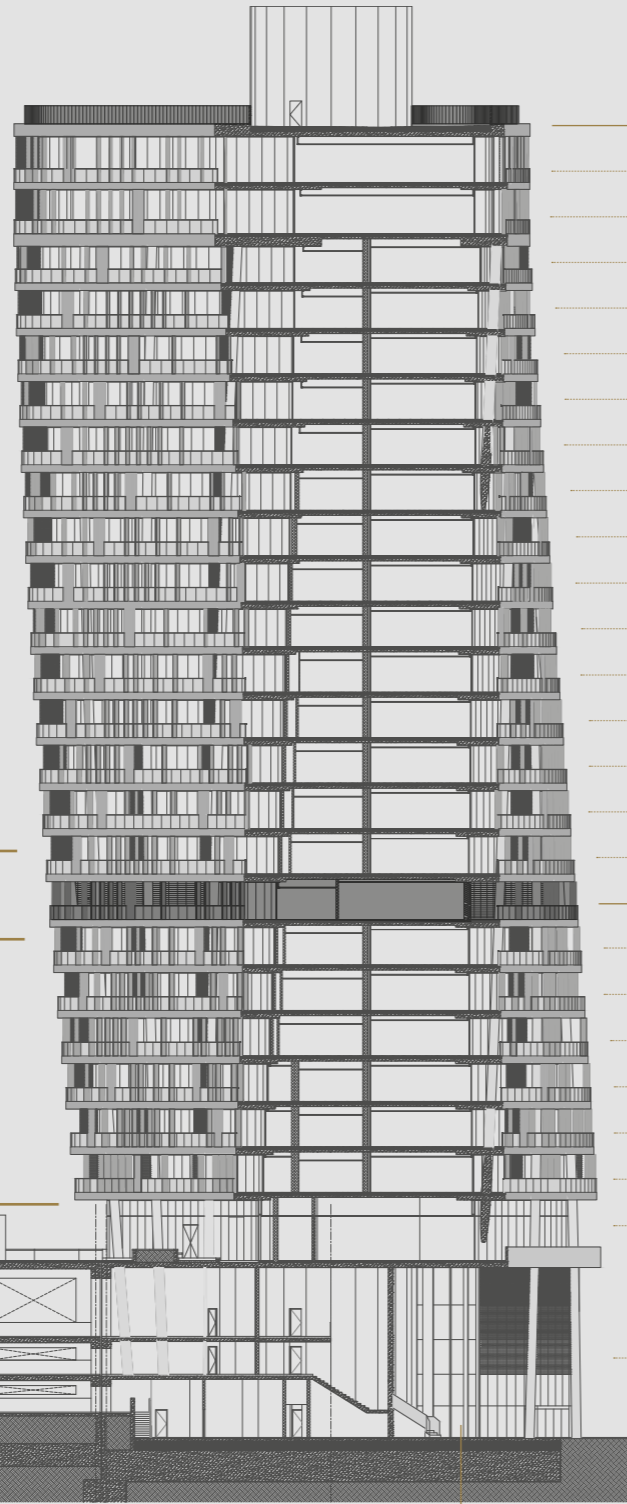

RETAIL SHOPS

SWIMMING POOL

CAR PARK

MAIN ENTRANCE
LOBBY

ROOF TOP / MECHANICAL FLOOR

FLOOR 26

FLOOR 25

FLOOR 24

FLOOR 23

FLOOR 22

FLOOR 21

FLOOR 20

FLOOR 19

FLOOR 18

FLOOR 17

FLOOR 16

FLOOR 15

FLOOR 14

FLOOR 13

FLOOR 12

FLOOR 11

MECHANICAL FLOOR 10

FLOOR 9

FLOOR 8

FLOOR 7

FLOOR 6

FLOOR 5

FLOOR 4

POOL DECK, GYM & SPA - FLOOR 3

CAR PARK - GROUND FLOOR, FLOOR 1 & FLOOR 2

LOBBY - GROUND FLOOR

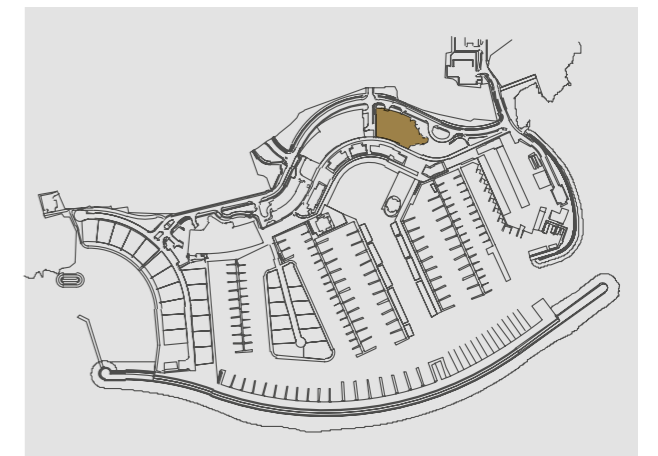

The East Tower, located in the commercial hub of the marina, offers luxury vibrant living.

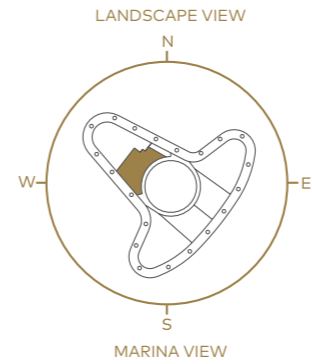

AVAILABLE ON FLOORS
4-6, 8-14, 17-19 & 21

1A

BEDROOMS	1
BATHROOMS	1
Internal area	68m ² / 732ft ²
Covered verandas	17m ² / 183ft ²
Total covered area	85m ² / 915ft ²
Guest WC	1
Parking space	1

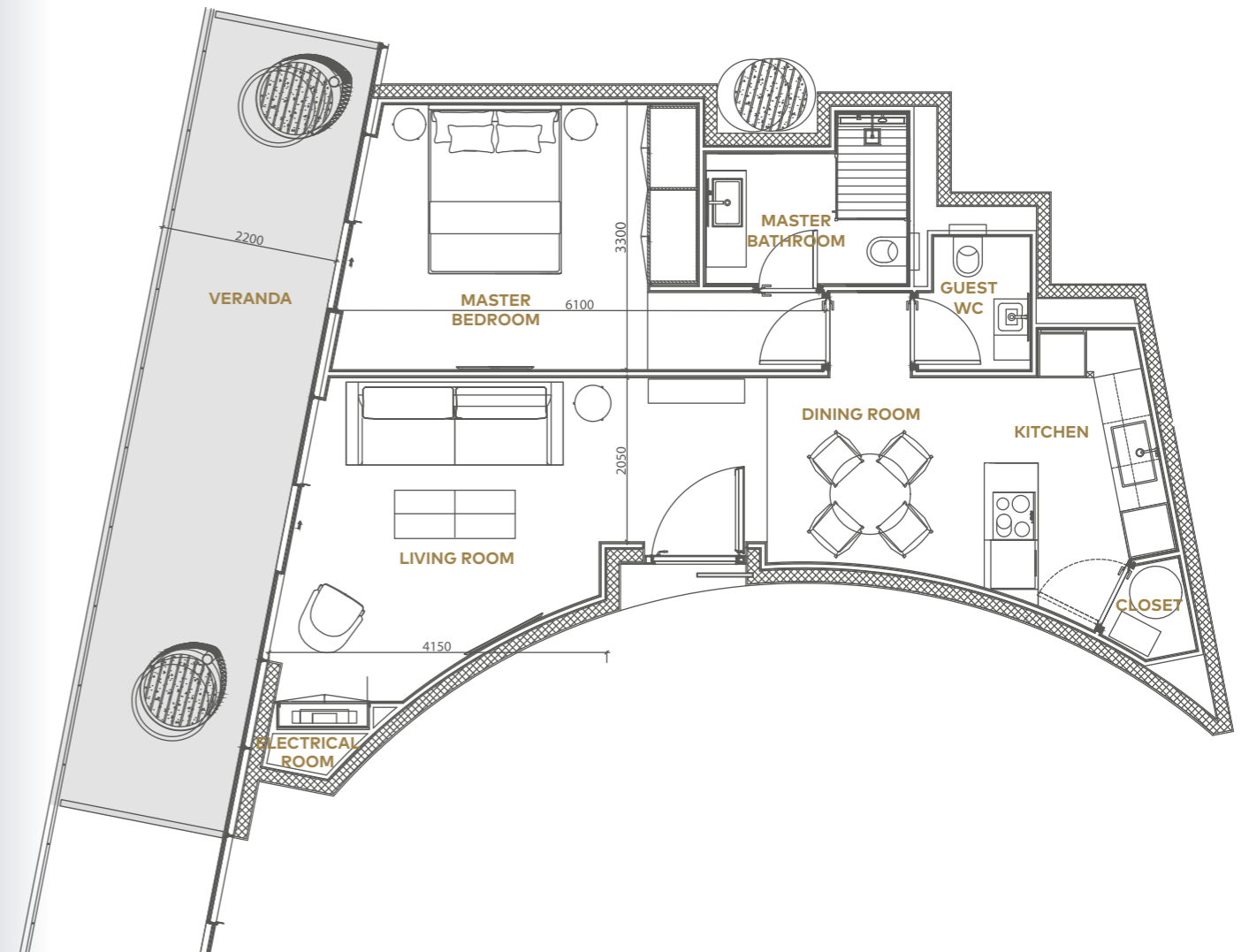

2A

BEDROOMS 2

BATHROOMS 2

Internal area	89m ² / 958ft ²
Covered verandas	26m ² / 280ft ²
Total covered area	115m ² / 1,237ft ²
Guest WC	1
Parking space	1

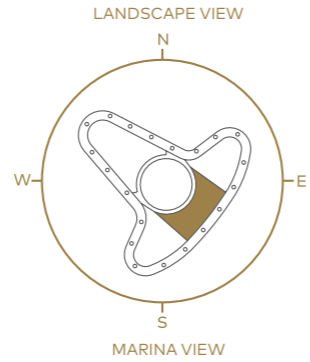

AVAILABLE ON FLOORS 5-24



2B

BEDROOMS 2

BATHROOMS 2

Internal area	98m ² / 1,054ft ²
Covered verandas	27m ² / 291ft ²
Total covered area	125m ² / 1,345ft ²
Guest WC	1
Parking space	1

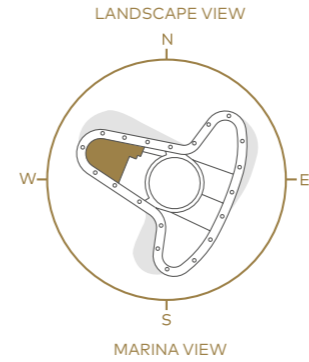

AVAILABLE ON FLOORS 4-6, 8-14, 17-19 & 21

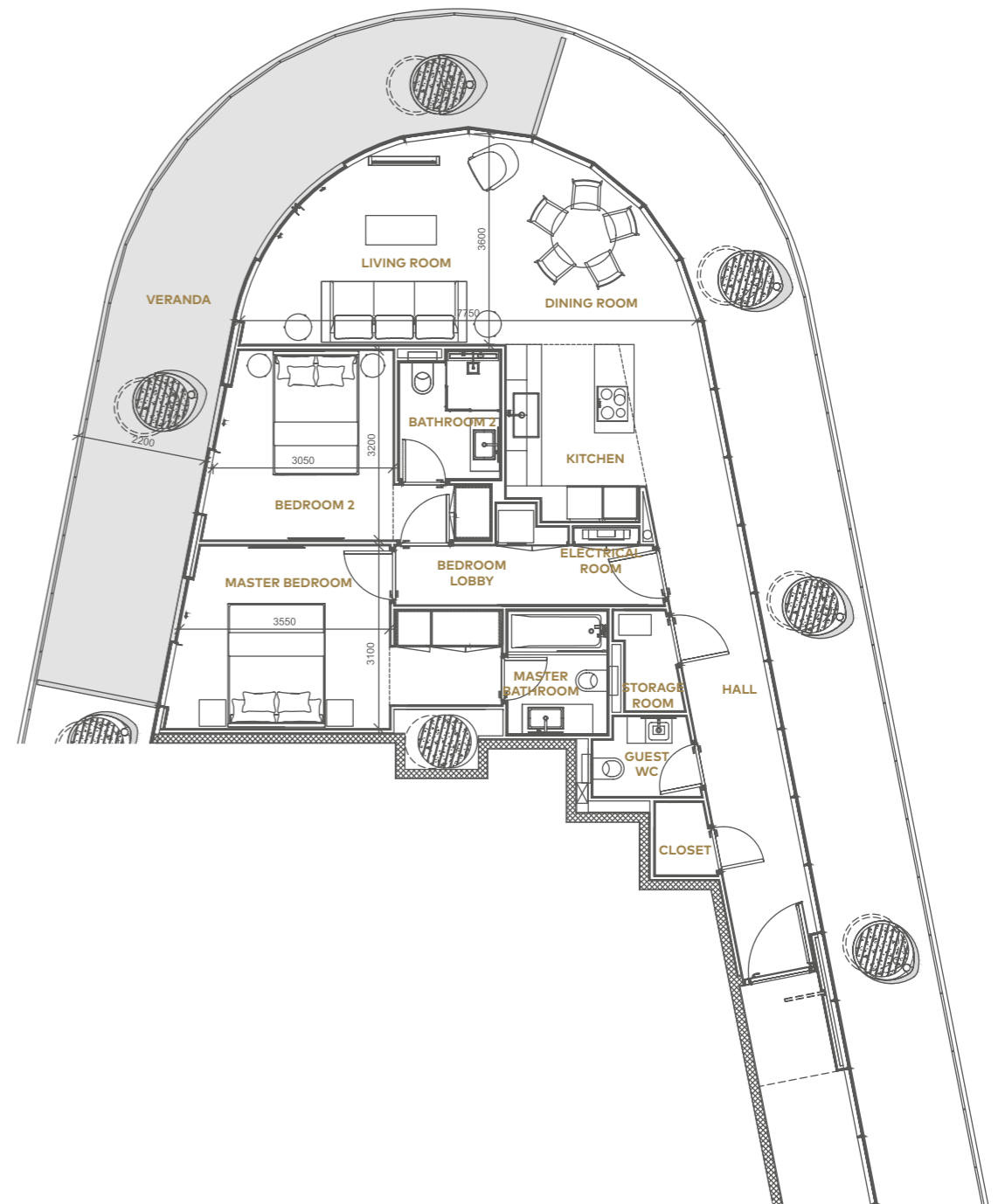

2Cw

BEDROOMS	2
BATHROOMS	2
Internal area	123m ² / 1,323ft ²
Covered verandas	34m ² / 366ft ²
Total covered area	157m ² / 1,689ft ²
Guest WC	1
Parking space	1

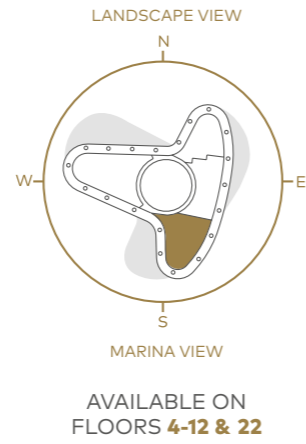

2Ce

BEDROOMS	2
BATHROOMS	2
Internal area	123m ² / 1,323ft ²
Covered verandas	34m ² / 366ft ²
Total covered area	157m ² / 1,689ft ²
Guest WC	1
Parking space	1

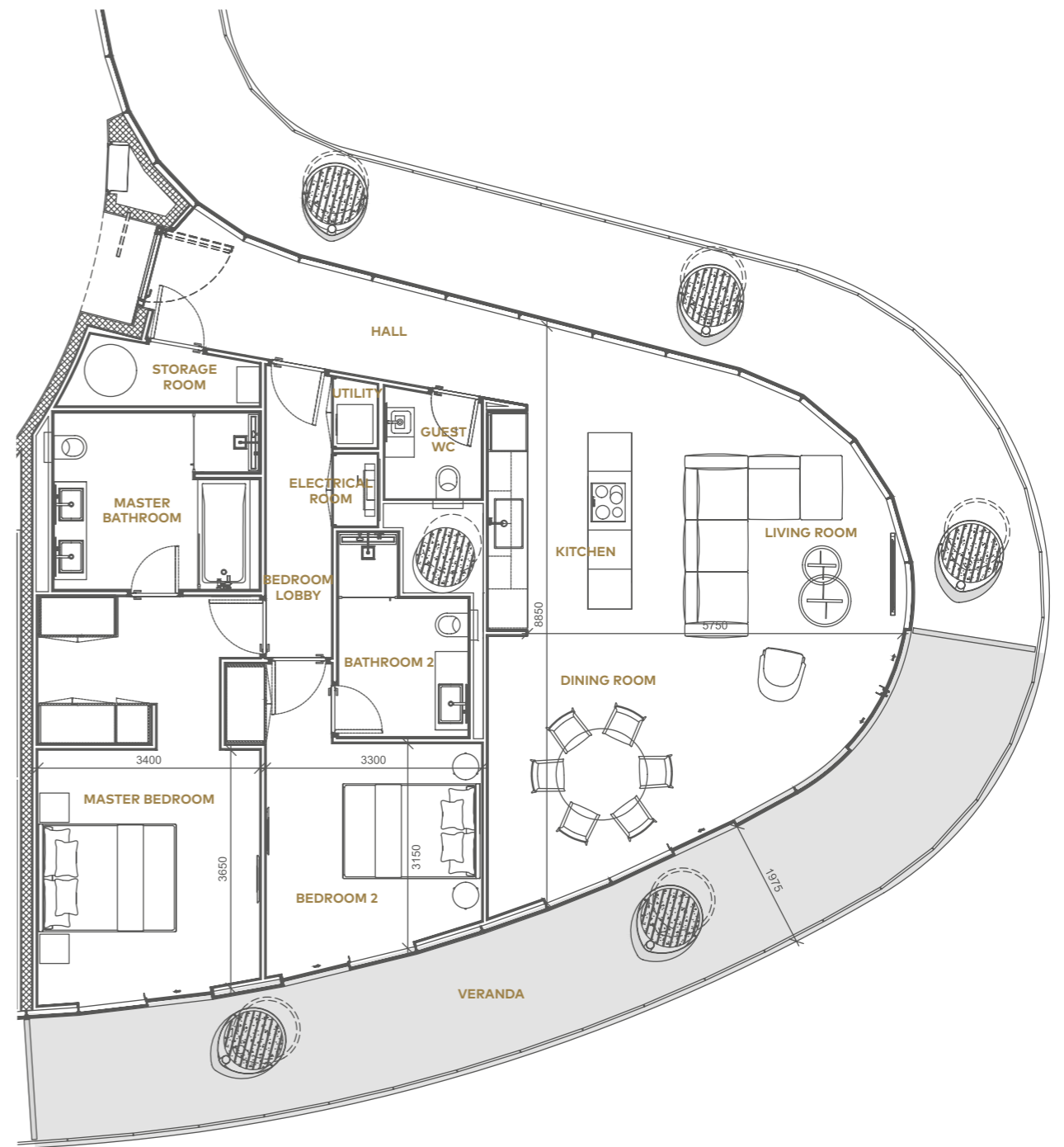
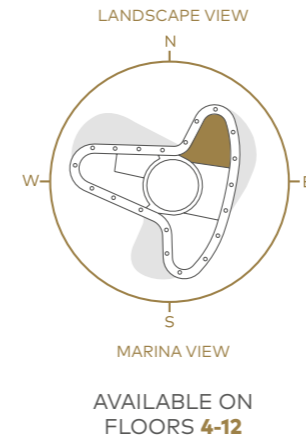

3Aw

BEDROOMS	3
BATHROOMS	2
Internal area	123m ² / 1,323ft ²
Covered verandas	34m ² / 366ft ²
Total covered area	157m ² / 1,689ft ²
Guest WC	1
Parking space	1

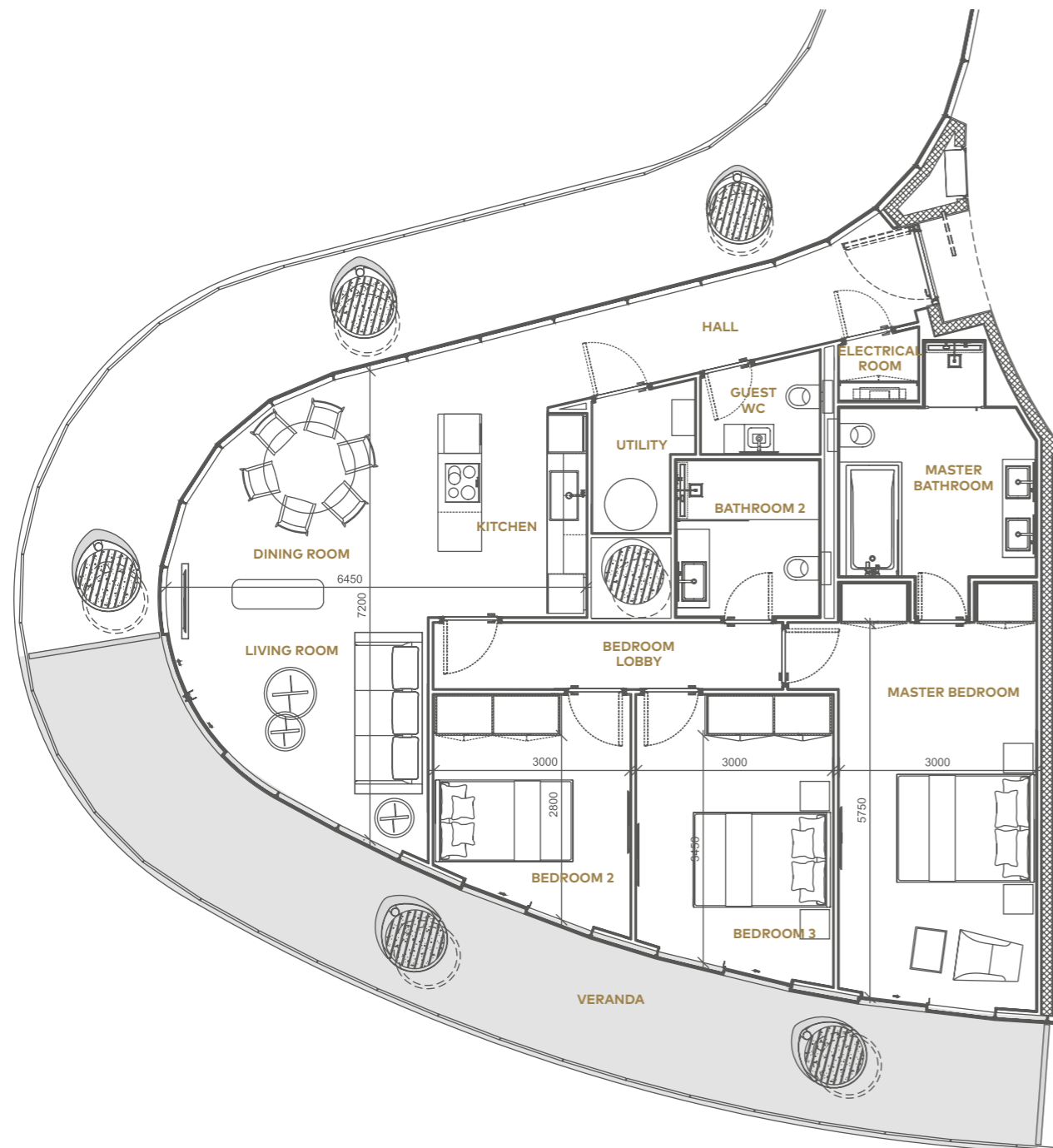
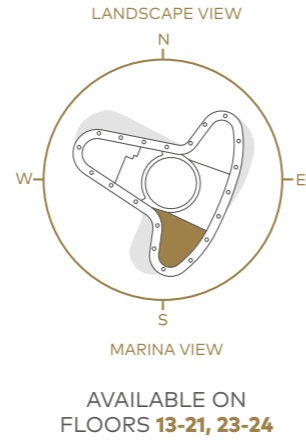

3Ae

BEDROOMS	3
BATHROOMS	2
Internal area	123m ² / 1,323ft ²
Covered verandas	34m ² / 366ft ²
Total covered area	157m ² / 1,689ft ²
Guest WC	1
Parking space	1

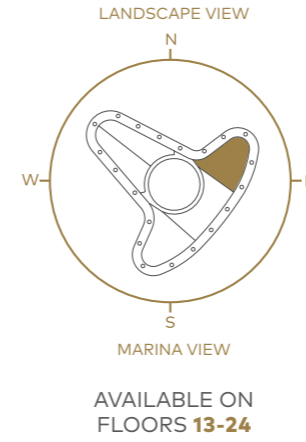

3B

BEDROOMS 3

BATHROOMS 3

Internal area 174m² / 1,872ft²

Covered verandas 44m² / 473ft²

Total covered area 218m² / 2,346ft²

Guest WC 1

Parking spaces 2

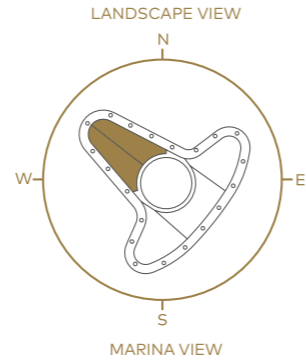

AVAILABLE ON FLOORS 7, 15-16 & 20

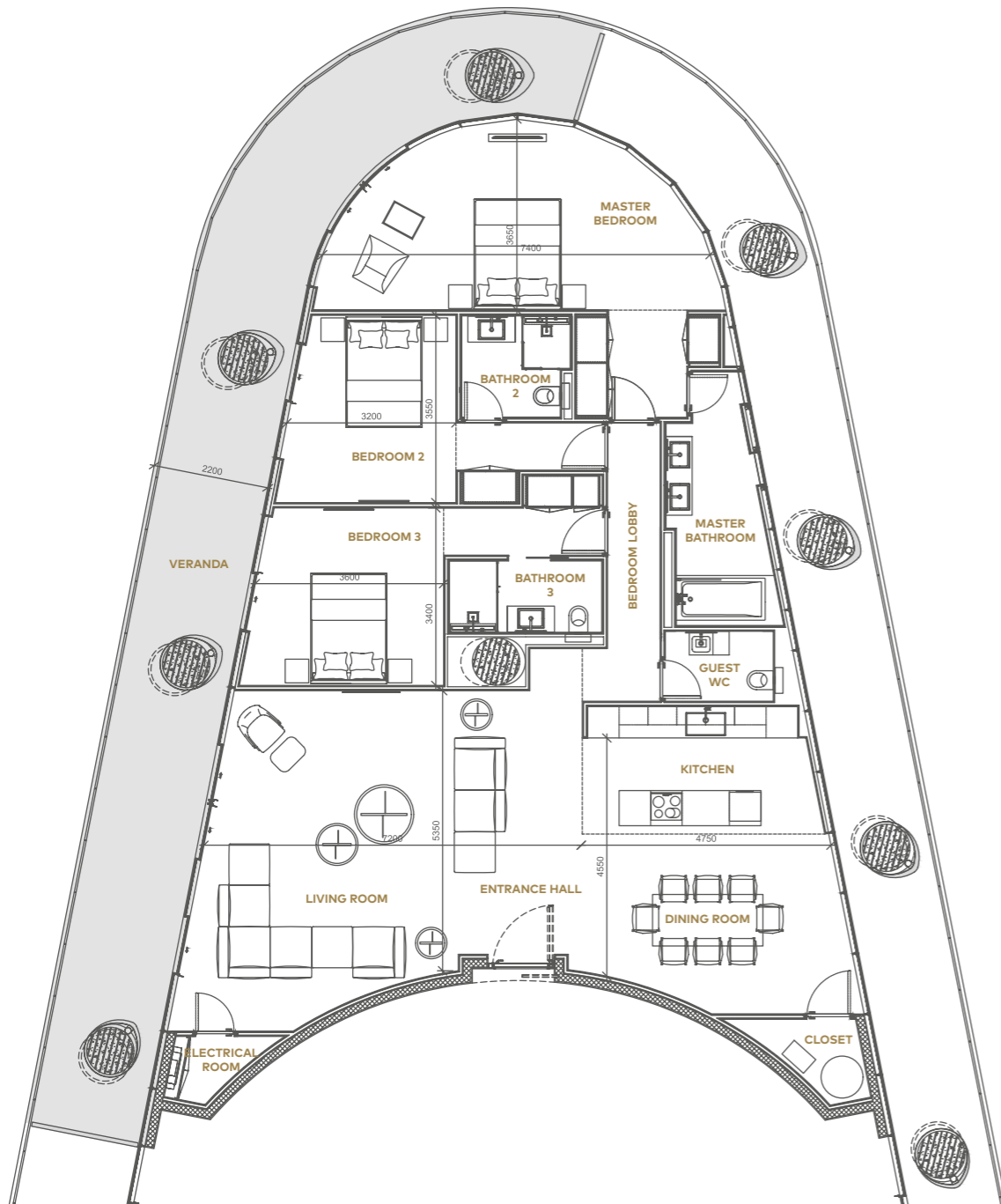

4A

BEDROOMS 4

BATHROOMS 4

Internal area 174m² / 1,872ft²

Covered verandas 44m² / 473ft²

Total covered area 218m² / 2,346ft²

Guest WC 1

Parking spaces 2

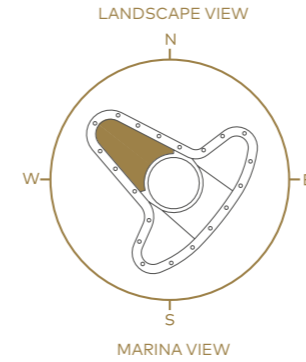

AVAILABLE ON FLOORS 22-24

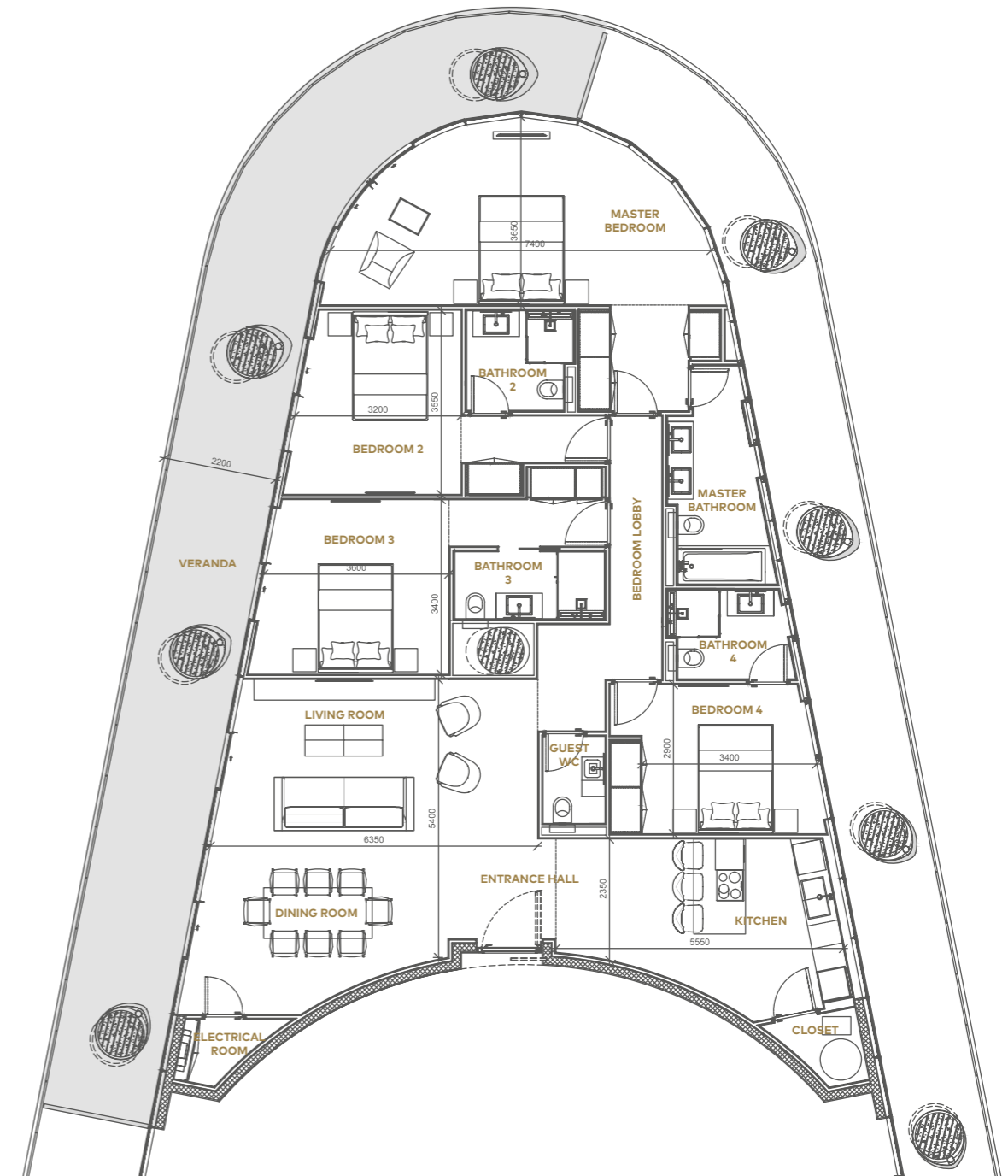

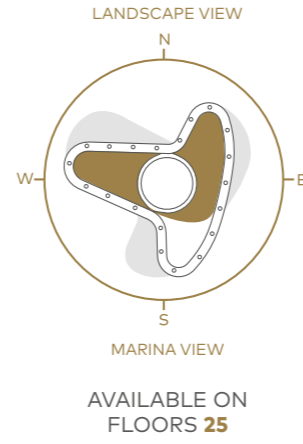

4B

BEDROOMS	5
BATHROOMS	5
Internal area	486m ² / 5,229ft ²
Covered verandas	296m ² / 3,185ft ²
Total covered area	782m ² / 8,414ft ²
Guest WC	1
Parking spaces	2

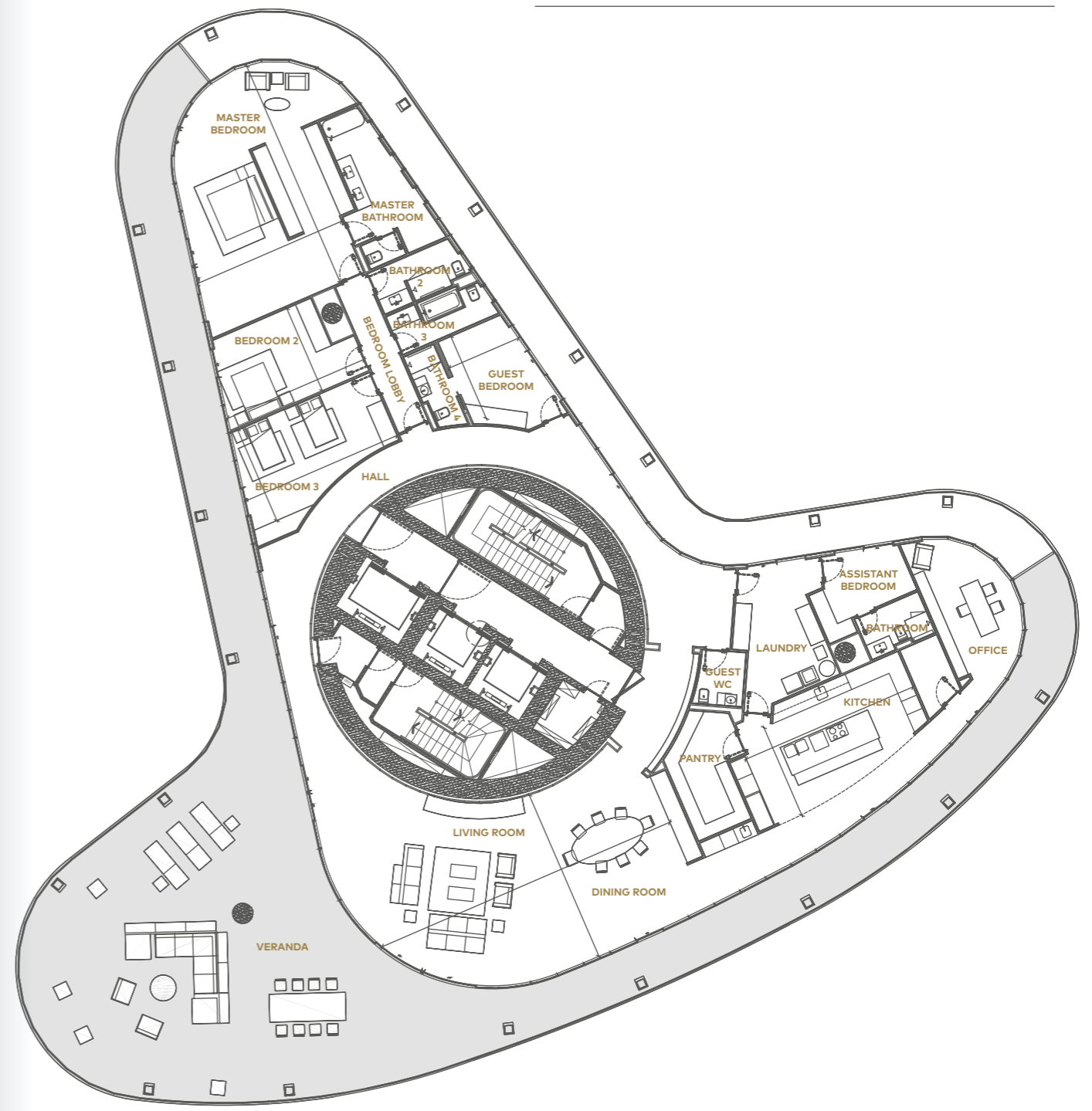

LUXURIOUS FINISHES



SAND

Light colours and soft tones, this tranquil style balances modern elegance with warmth and comfort creating a minimal yet sumptuous atmosphere.



WIND

Warm tones and calming colours. A comfortable chic aesthetic that marries simplistic elegance with sophisticated modern detailing.



WATER

Natural textures and shades of grey create a relaxing environment where clean lines and materials appear to be in constant motion.



HIGHEST QUALITY

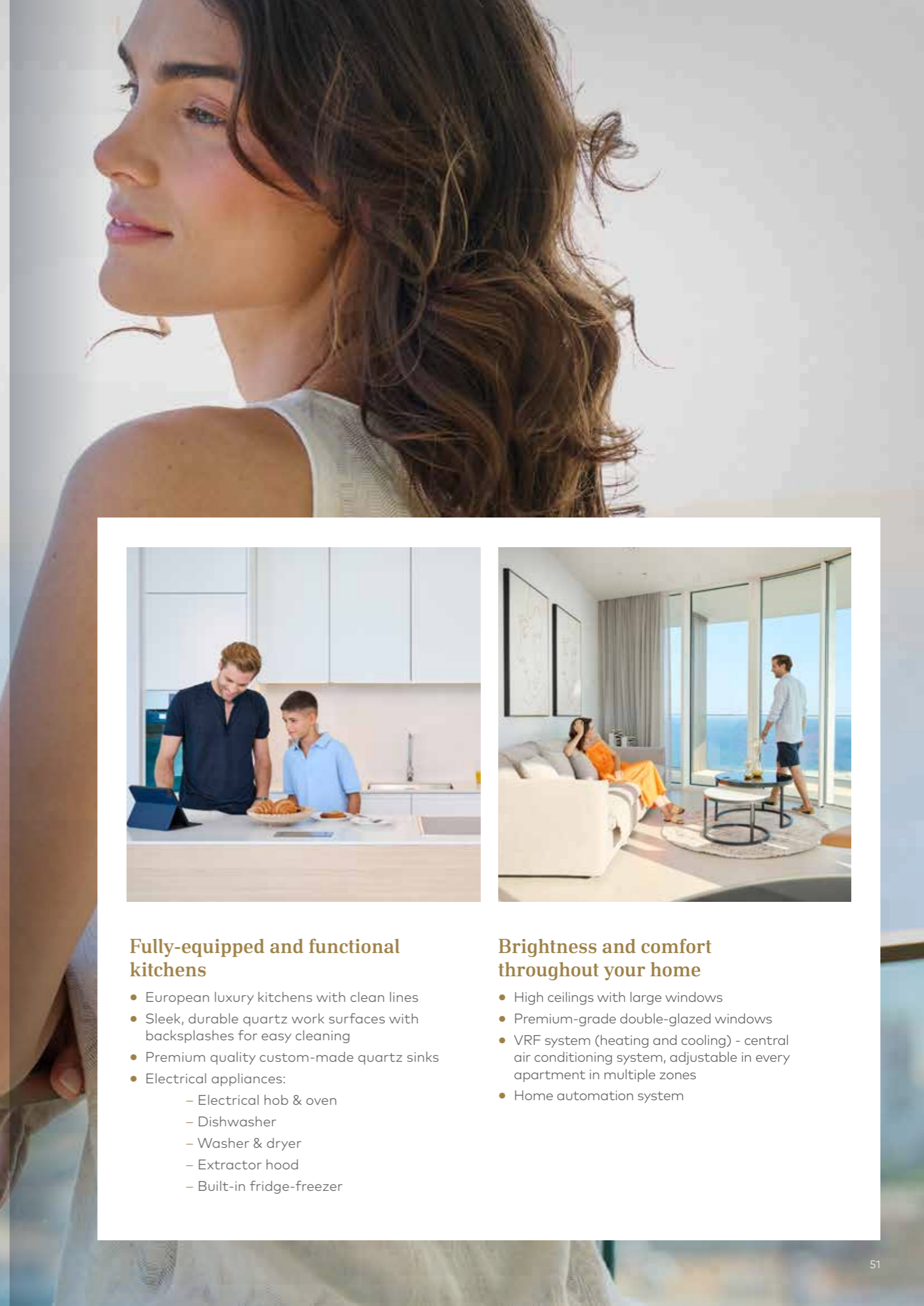

Durable and luxurious materials, fixtures and fittings

- Premium porcelain tile floors
- Solid-core doors with top-quality locks, door handles and hinges
- Central pressure system installation for hot and cold water

Bedrooms and bathrooms of the highest standard

- Imported high quality wardrobes
- En-suite bathrooms
- Premium porcelain tiles
- Top-quality imported sanitary fixtures with high quality vanity

ENERGY PERFORMANCE

All buildings comply with the local regulations of Energy Performance. The East Tower has a Category A high energy performance certificate.



Fully-equipped and functional kitchens

- European luxury kitchens with clean lines
- Sleek, durable quartz work surfaces with backsplashes for easy cleaning
- Premium quality custom-made quartz sinks
- Electrical appliances:
 - Electrical hob & oven
 - Dishwasher
 - Washer & dryer
 - Extractor hood
 - Built-in fridge-freezer

Brightness and comfort throughout your home

- High ceilings with large windows
- Premium-grade double-glazed windows
- VRF system (heating and cooling) - central air conditioning system, adjustable in every apartment in multiple zones
- Home automation system

How to
GET IN TOUCH



Masterplanners, Lead Architects and Marine Engineers

SmithGroupJJR

Local Architects

J+A Philippou, architects & engineers

Electrical & Mechanical Engineers

Caramondani Bros

Structural Engineers

Thornton Tomasetti

For more information and to
arrange a meeting, please contact:

T: +357 23 300 500

sales@MarinaAyiaNapa.com

MarinaAyiaNapa.com

52 Ayia Thekla Avenue, 5330, P.O.Box 30037, 5340, Ayia Napa, Cyprus



**AYIA NAPA
MARINA**

by **ΟΓΑ**

Ayia Napa Marina is a development by M.M. Makronisos Marina Limited. M.M. Makronisos Marina Limited has signed a concession agreement with the Cyprus Ministry of Energy, Commerce, Industry and Tourism on the 27th of April 2012 for Design, Finance, Build and Operation of the Ayia Napa Marina.

Ayia Napa Marina Legal Disclaimer

This brochure and the information therein, whether in written or pictorial form, do not constitute an offer or part of any offer or a legally binding document. The aim of this brochure is merely to provide and/or present an overall picture and preliminary information on the project. M.M. Makronisos Marina Limited provides no warranty or guarantee nor makes any statement or representation as to the accuracy, correctness, timeliness or completeness of the information and material included in this brochure. The information provided in this brochure is based on estimations and/or developments as at the date of editing hence may not be up to date.

Other Terms And Conditions:

M.M. Makronisos Marina Limited reserves the right to make minor alternations

All renderings and other visual material, designs, facades are for demonstration purposes only

All movable furniture, furnishings, drapery, decorative accessories/items and non-embedded lighting depicted in the visuals, are for illustrative purposes only and are not included in the property

Designed & produced by BrandDM, London.



